

## DDC4400e Automation Station

### Application

Controller with BACnet communication

- Stand-alone station for closed-loop and open-loop control, optimizing and monitoring functions
- Customizable plain text for every parameter
- Direct connection of the input and output signals
- 12 DDC closed-loop control plants for heating and ventilation, can be expanded with software objects
- PLC functions, free and as fixed macros (hardware objects)
- Software objects for increasing energy efficiency and energy optimization
- Weekly and annual schedules, battery-buffered clock
- Communication
  - Via TCP/IP, Ethernet cable (min. Cat5, 10/100 Mbit) to enable use of the existing infrastructure
  - Built-in remote control via PC with browser without additional software or mobile end devices
  - Native BACnet in accordance with DIN EN ISO 16484-5, BACnet IP and BACnet MS/TP
  - Up to 99 DDC4000 automation stations with bidirectional data exchange
- 2 buses (CAN-based), configurable for switch cabinet bus or fieldbus for connecting up to 63 fieldbus modules (FBM, FBU, FBR or DDC110) or up to 16 switch cabinet bus modules (BMD, BMA or SBM)
- Error message memory, event logging with date and time, incoming and outgoing messages are saved
- Forwards messages to printers, fax, GSM-SMS and e-mail.
- Trend value memory for max. 50.000 trend points.
- Configuration using modern, effective object structure, considerably reducing project planning time.
- Embedded Linux operating system for proven, stable use
- Backward-compatible with Kieback&Peter DDC3000 automation system
- Constant system monitoring of the bus communication and all connected DDC components, bidirectional data exchange possible.



## Content

## Page

Important Information Regarding Product Safety .....	2
Item .....	3
Technical Data .....	3
Dimensions .....	4
Installation Dimensions .....	5
Accessories (not included in delivery) .....	5
Connection .....	6
Installation .....	8
Mounting .....	9

Änderungen vorbehalten - Contents subject to change - Sous réserve de modifications - Reservado el derecho a modificación - Wijzigingen voorbehouden - Con riserva di modifiche - Innehåll som skall ändras - Změny vyhrazeny - Zmiany zastrzeżone - Возможны изменения - A változtatások jogát fenntartjuk - 保留未经通知而改动的权力

## Important Information Regarding Product Safety

### Safety Instructions

This data sheet contains information on installing and commissioning the product "DDC4400e". Each person who carries out work on this product must have read and understood this data sheet. If you have any questions that are not resolved by this data sheet, you can obtain further information from the supplier or manufacturer.

If the product is not used in accordance with this data sheet, the protection provided will be impaired.

Applicable regulations must be observed when installing and using the device. Within the EU, these include regulations regarding occupational safety and accident prevention as well as those from the VDE (Association for Electrical, Electronic & Information Technologies). If the device is used in other countries, it is the responsibility of the system installer or operator to comply with local regulations.

Mounting, installation and commissioning work on the devices may only be carried out by qualified technicians. Qualified technicians are persons who are familiar with the described product and who can assess given tasks and recognize possible dangers due to technical training, knowledge and experience as well as knowledge of the appropriate regulations.

### Legend



#### WARNING

Indicates a hazard of medium risk which can result in death or severe bodily injury if it is not avoided.



#### CAUTION

Indicates a hazard of low risk which can result in minor or medium bodily injury if it is not avoided.



#### CAUTION

Indicates a hazard of medium risk which can result in material damage or malfunctions if it is not avoided.



#### NOTE

Indicates additional information that can simplify the work with the product for you.

### Notes on Disposal

For disposal, the product is considered waste from electrical and electronic equipment (electronic waste) and must not be disposed of as household waste. Special treatment for specific components may be legally binding or ecologically sensible. The local and currently applicable legislation must be observed.

**Product Description****DDC4400e****Item**

DDC4400e Controller

**Technical Data**

Nominal voltage	<p>for controller (terminals 1 and 21):</p> <ul style="list-style-type: none"> <li>■ AC 24 V +/- 10%; 50 to 60 Hz; 18 VA; 0.75 A or</li> <li>■ DC 24 V +/- 10%; 9W; 0.4 A or</li> <li>■ DC 12V +/- 10%; 91 W; 0.75 A</li> </ul> <p>for binary inputs and outputs (terminals 41 and 61):</p> <ul style="list-style-type: none"> <li>■ DC 24V +/- 10%; 1.2 W; 0.05 A</li> </ul>																						
Fuses	Time-delay mains fuse 3.15 A																						
Inputs and outputs	<ul style="list-style-type: none"> <li>■ 32 BI/BO configurable, <ul style="list-style-type: none"> <li>8 BI (K1 to K8) for pulse counting up to 80 Hz</li> <li>BO: Voltage-free transistor output contact to 0 V = DC 24 V; 50 mA</li> </ul> </li> <li>■ 24 AI/AO configurable <table border="0" style="margin-left: 20px;"> <thead> <tr> <th style="text-align: left;"><b>Sensor type (AI)</b></th> <th style="text-align: left;">Value range and unit</th> </tr> </thead> <tbody> <tr> <td>0..10 V</td> <td>0 ..100%</td> </tr> <tr> <td>KP10; KP250</td> <td>-50 ..+150 °C</td> </tr> <tr> <td>Pt100; PT1000</td> <td>-100..+850 °C</td> </tr> <tr> <td>Ni100</td> <td>-50..+150 °C</td> </tr> <tr> <td>Ni1000 (DIN)</td> <td>-50..+150 °C</td> </tr> <tr> <td>Ni1000 (L&amp;G)</td> <td>-50..+150 °C</td> </tr> <tr> <td>NTC 1,8K; NTC 5K</td> <td>-50..+150 °C</td> </tr> <tr> <td>NTC 10K</td> <td>-40..+150 °C</td> </tr> <tr> <td>NTC 20K</td> <td>-30..+150 °C</td> </tr> <tr> <td>NTC 10KPRE</td> <td>-50..+150 °C</td> </tr> </tbody> </table> <p style="margin-left: 20px;"><b>Output (AO)</b></p> <p style="margin-left: 20px;">DC 0 V to 10 V; 2.5 mA</p> </li> <li>■ Separate auxiliary power (terminal 16) DC 10 V; 50 mA for connecting external setting knobs</li> </ul>	<b>Sensor type (AI)</b>	Value range and unit	0..10 V	0 ..100%	KP10; KP250	-50 ..+150 °C	Pt100; PT1000	-100..+850 °C	Ni100	-50..+150 °C	Ni1000 (DIN)	-50..+150 °C	Ni1000 (L&G)	-50..+150 °C	NTC 1,8K; NTC 5K	-50..+150 °C	NTC 10K	-40..+150 °C	NTC 20K	-30..+150 °C	NTC 10KPRE	-50..+150 °C
<b>Sensor type (AI)</b>	Value range and unit																						
0..10 V	0 ..100%																						
KP10; KP250	-50 ..+150 °C																						
Pt100; PT1000	-100..+850 °C																						
Ni100	-50..+150 °C																						
Ni1000 (DIN)	-50..+150 °C																						
Ni1000 (L&G)	-50..+150 °C																						
NTC 1,8K; NTC 5K	-50..+150 °C																						
NTC 10K	-40..+150 °C																						
NTC 20K	-30..+150 °C																						
NTC 10KPRE	-50..+150 °C																						
Bus connection / interfaces	<ul style="list-style-type: none"> <li>■ Ethernet RJ45 Enables operation of up to 99 DDC4000 automation stations, users can establish worldwide network via active network components, BMS and BACnet client connection, 10/100 Mb/s, TCP/IP</li> <li>■ 2 CAN buses, configurable as fieldbus or switch cabinet bus Fieldbus; F-bus: 63 fieldbus modules (FBM), 2,000 m; 20 kBd, CAN Switch cabinet bus; SBM bus: 16 switch cabinet bus modules (SBM or BMA/BMD); 200 m; 40 kBd, CAN</li> <li>■ USB socket (behind the front panel) for USB memory stick: Update, backup/restoration</li> <li>■ Serial RS232 Modem, fax, printer or remote control for DDC3000 automation station</li> <li>■ RS485 for BACnet MS/TP: 32 devices, 1000 m, up to 115 kBd, routing in accordance with BACnet/IP</li> </ul>																						



**NOTE**

The RS232 or RS485 interface is activated by means of configuration. Only one of the two interfaces can be used. The default setting is inactive. You can find further information in the DDC4000 project planning documentation Section "SY\_Serial" Objects

Memory	4 GB flash; 512 MB RAM
Operating system	Embedded Linux
Mains failure data backup	7 years, battery-buffered clock module
Overvoltage category	III
Rated impulse voltage	800V
Level of contamination	2
How It Works	Type 1
Degree of protection	IP20
Ambient temperature	0 °C..50 °C
Ambient humidity	During operation: 20% to 80 % r.h., non-condensing Out of operation: 5% to 90% r.h., non-condensing
Housing	19" plastic short enclosure, quadruple enclosure with base and extra connections for Ethernet RJ45 and RS232 WxHxD: 202 x 132 x 137 mm
Front panel cutout	200.4 mm x 112.0 mm
Weight	1.15 kg
Label	CE

**Dimensions**

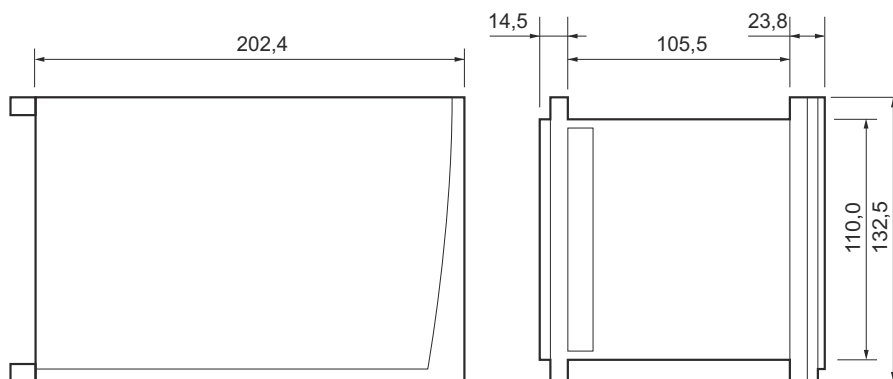

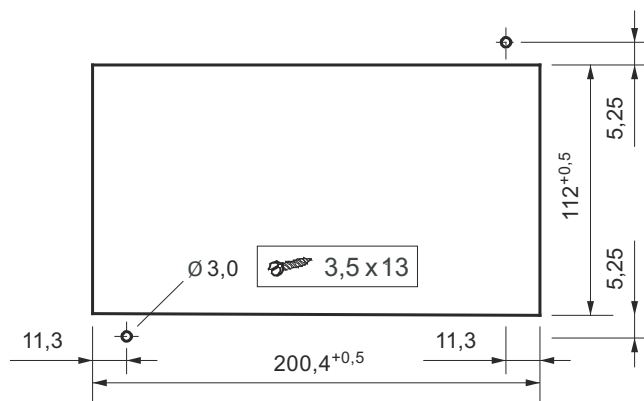
**Product Description****DDC4400e****Installation Dimensions****Accessories (not included in delivery)**

- Z23** Wall bracket for the DDC3000/DDC4000 automation station  
Installation note 2.85-10.023-99 contains further information on the installation (included with accessory Z23).

Connection

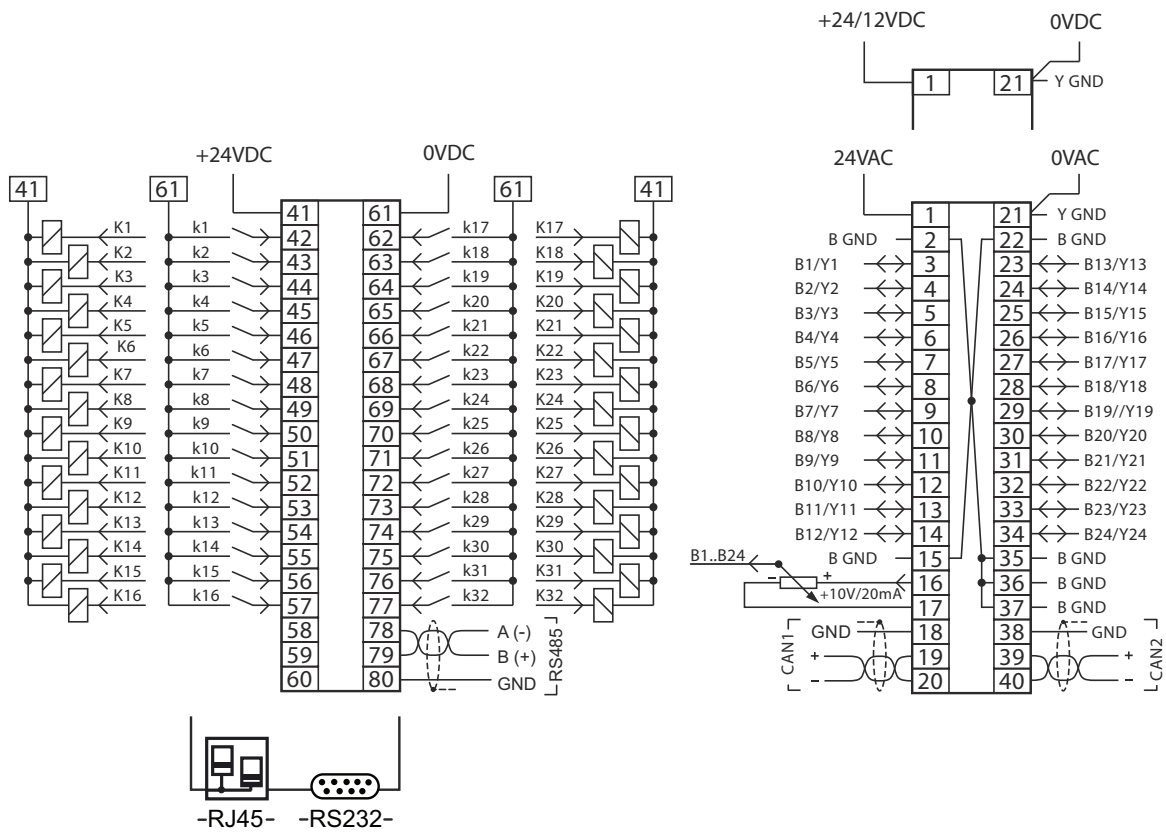

**CAUTION**

Always use separate power supply units for supplying power to the controller (terminals “1” and “21”) and the binary inputs and outputs (terminals “41” and “61”).



**CAUTION**

Ensure that no third persons can access your data during data transfer.  
Only use secure solutions when connecting to public networks (VPN).

Sensor and actuator connection

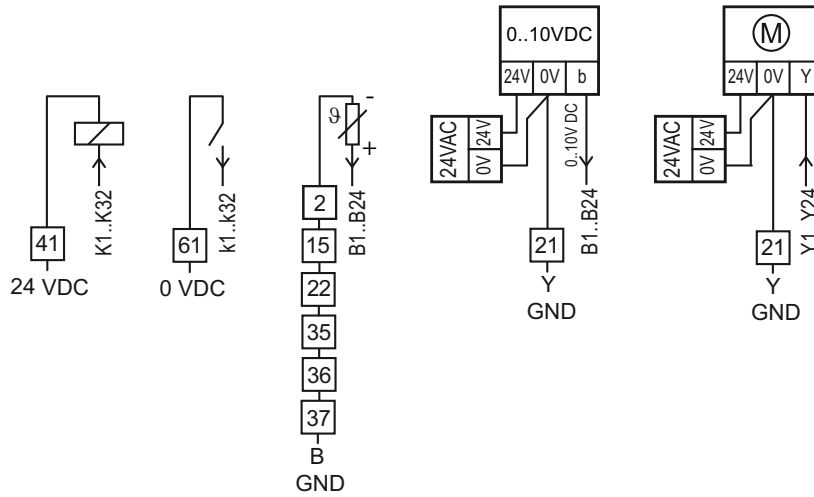

**CAUTION**

The GND wiring specified in the wiring diagram (Y GND, K GND, B GND) must be observed. Incorrect GND wiring may lead to errors in measurement.

---

## Installation

---



### CAUTION

Switching on the power supply of unparameterized products can lead to unforeseen consequences such as malfunctions or material damage.

Switch on the power only after the device has been configured by the commissioning technician.

---

### CAN bus

When connecting the CAN bus, use a cable with 2 x 2 leads stranded into a pair with plastic insulation and electrostatic shielding with a lead diameter of at least 0.8 mm. Use a stranded pair of wires for the data lines (+ and -) and another free wire for the ground (0).

At the end of the CAN bus (furthest point from the controller), install a terminating resistor of about 180 ohms between the two data lines (+ and -). The terminating resistor is included with the controller.

- When using CAN bus as a fieldbus, the maximum cable length is 2,000 m.
- When using CAN bus as a switch cabinet bus, the maximum cable length is 200 m.
- Make sure to observe the line topology for the CAN bus.

### RS485 for BACnet MS/TP

When connecting the MS/TP bus, use a cable with 2 x 2 leads stranded into a pair with plastic insulation and electrostatic shielding with a lead diameter of at least 0.8 mm and a characteristic impedance between 100 and 130 ohms.

Use a stranded pair of leads for the data lines and another free lead for the ground connection.

Observe the polarity of the data lines of the MS/TP. Terminal "78" supplies the inverted signal, it is usually labeled with A (-). Terminal "79" supplies the non-inverted signal, it is usually labeled with B (+). Terminal 80 is used for the ground connection.

At the start and end of the MS/TP bus, install a terminating resistor of ideally about 120 ohm between the two data lines.

The DDC4000 is fitted with a 120 ohm terminating resistor that can be activated via configuration. Further information can be found in the DDC4000 project planning documentation

Foreign devices often enable a switchable terminating resistor. Refer to the data sheet or the respective manufacturer's manual for further information.

Use bias resistors to maintain the bus idle level at a defined high level and to prevent noise being misinterpreted as a data signal. We recommend that you use network bias resistors on the first and last device on the bus.

A maximum of 2 devices on the bus may be equipped with network bias resistors.

The DDC4000 is fitted with a 680 ohm bis resistor that can be activated via configuration. Further information can be found in the DDC4000 project planning documentation

Foreign devices often offer optionally switchable bias resistors.

- The maximum possible bus length is 1000 m.
- A maximum of 32 devices can be operated on a bus segment.
- Observe the line topology for the RS485 bus.



Mounting



**WARNING**

Contact with live parts of electrical domestic installation can cause death due to electric shock. Mounting/removal may only be carried out when power is switched off.

**Front installation**

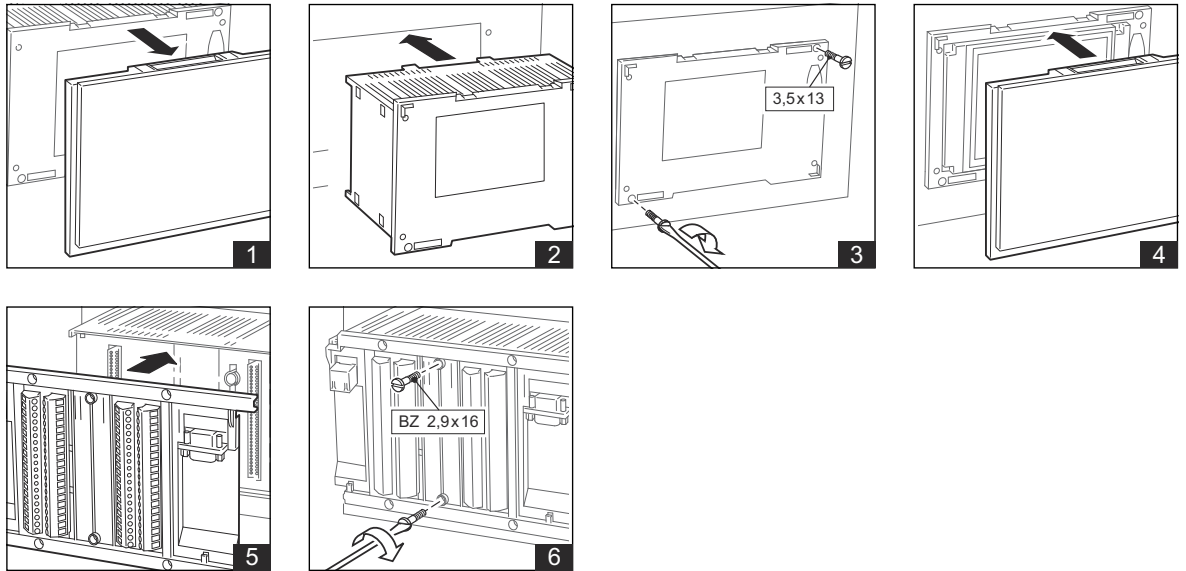

**19" KA rack**

