

www.bacnetinternational.org

BACnet
International



Issue 20

JOURNAL

This Issue

BACnet in Today's World



Global Testing of the Global Standard



BTL CERTIFICATION

Your Best Path to BACnet Interoperability



If you are involved with building controls and automation, rely on the BTL Certification program to make sure the products you buy have been rigorously tested for compliance to the BACnet standard. BACnet is the world's standard for building interoperable solutions but it only works when products are correctly implemented. When you buy products that are not correctly implemented it can cost you a lot in terms of system integration time and money.

The BTL Certification program is operated by the BACnet Testing Laboratories (BTL), which is overseen by BACnet International. BTL was established more than 15 years ago to lead compliance testing and host interoperability events. To achieve certification, BACnet products must successfully undergo rigorous industry-standard testing conducted by recognized, independent testing organizations.

Users can identify tested products through the BTL Listing Service which is available to users globally at no cost. The service supports searching for specific products as well as browsing through products with different capabilities. In addition, the listing service provides detailed information on the specific tested capabilities of each product.

Accelerate your system integration and avoid unnecessary integration costs. Require all BACnet products in your system be fully tested. Ensure every product displays the BTL Mark or is verified through the BTL Listing Service.

There are over 1100 products in the BTL Listings of Tested Products Database with more being added every month. **Find tested products to fit your needs at www.bacnetlabs.org.**



BACnet Testing Laboratories
bacnetlabs.org
info@bacnetinternational.org
+1-770-971-6003

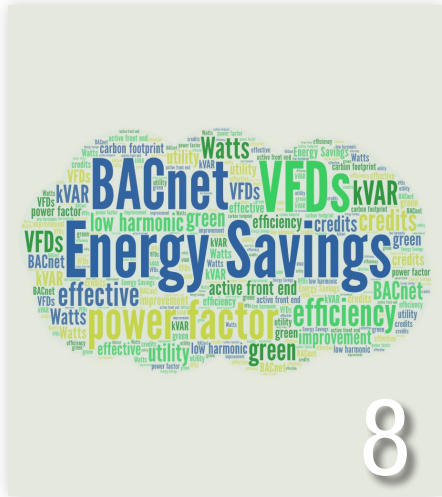

© ABB



© HRS Real Estate AG



© Coleman Brumley

Letter from the President	4
Feature Articles	
Fast and Efficient Integrations Thanks to BACnet	5
Using BACnet and Active Front End VFDs to Lower Your Utility Bill	8
Deploying and Maintaining BACnet Systems in Today's Networks	10
Success Stories	
Hong Kong Road to Smart City Passes Through Massive Data Integration	14
Energy Management at the Empire State Building	16
Bergwelt Grindelwald: Rustic Chalet Charm Meets High-Tech Room Automation	18

Departments

New Chairman of ASHRAE SSPC 135: Coleman Brumley	19
New to the BACnet International Family	20
BACnet International News	
Expand Your BACnet Knowledge!	22
BTL Testing Updates	22
New BTL-Listed Products	24
Calendar of BACnet International Events	25
Legal Notice	26



Cover picture:

\$800,000 annual energy savings at the Empire State Building

Content
Issue 20 | November 2021

All issues can be downloaded from www.bacnetinternational.org/page/journal

Letter from the President

Dear Reader,

Does it seem to you that building automation is getting more complicated? Not that it was ever simple, of course. But over the last 10 years we have seen constant evolution in building requirements relating to energy, occupant wellness, sustainability, physical security and others. And those have been paralleled by a rapid introduction of technologies including mobile devices, data analytics, cybersecurity, IoT and more. The result is growing complexity in specifying, building, operating and maintaining building automation systems. Which is perhaps our biggest obstacle to achieving broader adoption.

In building automation, technology alone does not lead to widespread adoption. There is no “build it and they will come” model in our industry. Because technology is just a tool, not a goal. It is only useful to the extent that it is adopted and actually used. And that is where complexity gets in the way. We have all seen situations where a control system was left “in hand” because the operator did not know how to get the automation system to do what they needed it to do. Or, at least what they thought they needed it to do. If automation systems can be designed around reducing complexity, we would see increased benefits which would drive broader adoption. Evidence of this dynamic is all around us.

For example, prior to the launch of the first smartphone in 2007 (not that long ago), if you wanted to capture a short video clip in HD and post it to the web, you had to deal with a lot of technical

complexity. Special hardware and software were required, along with the knowledge and skill to use them. Today, no special knowledge is required, and people do it millions of times a week using their phones. And that is not because the technical requirements are any simpler. In fact, it is probably more complex than ever with highly sophisticated compression algorithms and streaming protocols. But the key is that enormous effort has gone into hiding that complexity behind a simple user experience. The challenge for us is to do the same thing in building automation.

Simplifying the user experience while technical complexity increases requires purposeful innovation targeting users along the whole value chain. In this context, users of BAS technology include specifiers, control system designers, integrators, and building operators because they all need to interact with it in some way. If any one of them find it too complex to deal with, effective adoption falls off. Achieving our energy, occupant wellness, sustainability, physical security, cybersecurity, and other goals requires more focus on making BAS easy to use. That is a challenge all of us in the industry need to take as our own.



© McMillan

Andy McMillan
 President and Managing Director BACnet International
 andym@bacnetinternational.org | www.bacnetinternational.org



ABOUT THE AUTHOR

Andy McMillan is President and Managing Director of BACnet International, where he works with users and suppliers to expand and enhance the BACnet community. Previously he served as President of a building automation and energy management business unit of Philips Lighting.

Fast and Efficient Integrations Thanks to BACnet



The integration problem: multiple systems providing services to the building users are not capable of communicating with each other by themselves. © HMS Industrial Networks, SLU

Having a general overview and full control of all the elements in a building provides a lot of benefits to both factories and buildings, but it also implies some tough work for the integrator.

One of the most significant problems that integrators must deal with is how to set up signals and bindings when integrating different devices in a building management system (BMS), SCADA, PLC or similar. Thanks to the possibility of scanning BACnet networks and discovering devices and their elements, BACnet integrations can be done in a fast and efficient way and with less headaches for the integrator compared to other integration protocols.

On the Run: Building from Scratch

More often than what is desired, integrators face the problem of finishing their projects before the bell rings. Projects pass through different phases and one of the last, and unfortunately one that usually gets less attention, is the integration stage. Contractors and owners put a lot of effort

into the first stages, where structural issues and material selections steal a lot of energy from the people in charge. Then, once we get to the final stage, everybody wants everything up and running as soon as possible so there's hardly any energy spent on that stage. I'm sure you know what we are talking about.

It is common in these scenarios, as many of our customers have shown, that integrators get to the building or facility and feel the pressure of being the ones in charge to finish everything on time and make it work. Also, in these situations, it is very common that information has not been supplied properly, so the integrator is on his/her own with simply the device manuals and some CVS or Excel sheets. It's under these circumstances where BACnet can give us a hand, with the most potential coming from the scanning feature, as the integrator will be able to discover devices and their objects in almost no time.

We can face two different types of integrations: having a BMS, Central System, Scada, PLC or

similar that talks BACnet and requires control of third-party devices that may talk any other protocol (either standard or proprietary), or just the contrary, having a BMS, Central System or similar talking any standard or proprietary protocol that requires the integration of BACnet devices.

In the first case, where the supervision and control remain in the BACnet side, BACnet servers are commonly used. Those devices provide connection to physical elements (valve actuators, air conditioners, meters, etc), which, at the same time, talk their own protocol language; or protocol converters, which provide communication from any other protocol (Modbus, KNX, ASCII, EthernetIP, Profinet, etc.) to BACnet. In such cases, it is important that the control or supervision system include this scanning mechanism, so object names, descriptions and other properties can be assigned easily.

In the second case, where the supervision and control are not in the BACnet side, BACnet clients are commonly used to integrate BACnet devices into these systems. In that case, the scanning function



CO-SPONSORS



Recharged.
Renewed.
Ready to
Rock.

LAS VEGAS
JAN 31 – FEB 2
2022

shall be present in the protocol translator to read all of the BACnet information from a BACnet server and convert it to any other protocol by doing the appropriate bindings and conversions.

Having hundreds or thousands of signals to integrate can really make the process very hard and complex if you need to collect all information from manuals, other integrators/installers, specifications from the project designer, or by some other means. Nonetheless, with the appropriate scanning tool, integrators will be able to find all devices connected to the BACnet network or segment and discover all its Objects too. This converts a hard task in other protocol integrations where you need to write down all addresses of the devices and their signals into a simple scanning and selection process for the BACnet case.

Moreover, as this feature is present as a standard mechanism, all manufacturers are able to include that at some point. Therefore, it is not a limitation for them, but a nice piece of help for those using their solutions.

The Perfect Partner

Even if we are lucky enough to have everything prepared in plenty of time, sometimes things do not work as they are supposed to. Having a protocol which is able to help you during the integration and also during the commissioning stage is very helpful.

Consider the case of having all signals from the manual implemented in your system, and, once you are in place, control and supervision are not as expected: values do not match, control is not possible. Here is where the scanning process can provide more help. Thanks to this feature, you can double check if the information provided or used during the configuration stage was appropriate, or maybe it was mistaken. Along with the power of finding devices and objects for faster integrations, BACnet's troubleshooting functionality is something most customers highlight and are thankful for, compared to other protocols or solutions.

Hello, is someone there?

But how is all this done? The mechanism is quite simple: ask what you need. Thanks to the BACnet protocol, devices can be easily discovered using "Whols" and "I-AM" messages. It's as simple as that. Just like when you move to a new neighborhood and you have to introduce yourself and start meeting new people. Of course, this is just the beginning. By using these messages, we will simply find the different devices and we will recognize each other. After that, we will need to look for more detailed information: Objects and its property values. Then, the next common-sense question: "WhoHas" with its corresponding answer "I-Have". Here is where the whole thing gets more interesting, with the extra step of having to find the signals we need to bind or integrate in our project.

If you want more detailed and technical information on how these can be done, you can check it out on [The BACnet Institute](#).

Nonetheless, everything has its own pros and cons. Being able to find devices and their objects automatically is not free and has some implications.

Firstly, we need to consider that all these discover messages usually work in a Broadcast mode, so that means that network traffic may be overloaded. Therefore, we need to make sure that we set up devices as efficiently as possible and we do not constantly keep sending these discover messages.

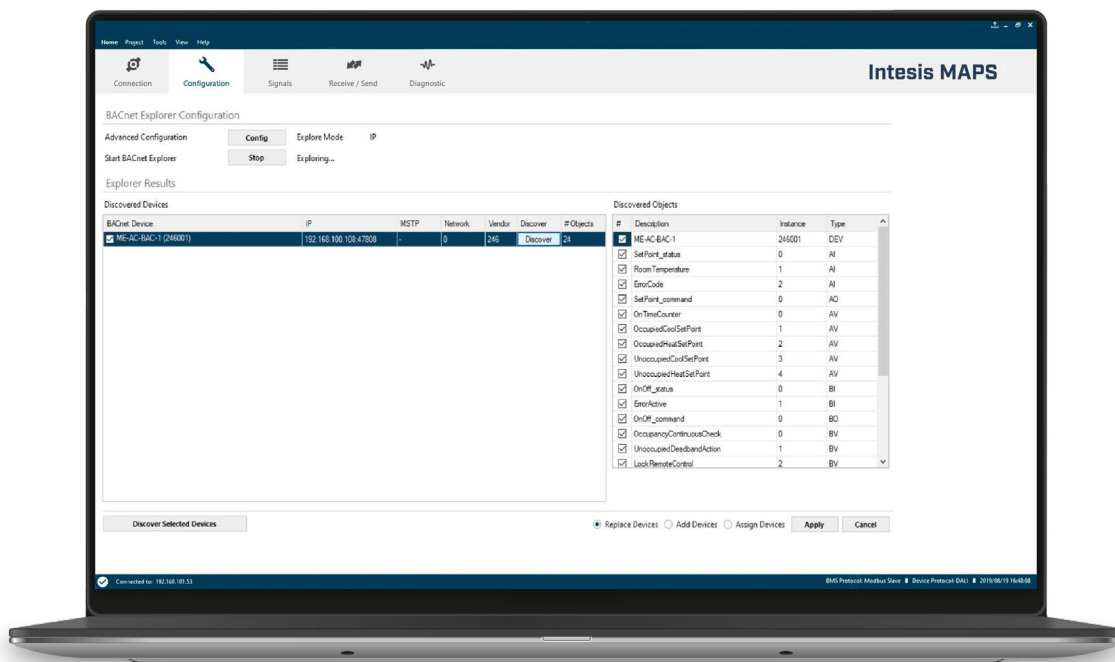

Intesis MAPS: The most powerful configuration tool common for all Intesis gateways enabling a fast and simple commissioning.
© HMS Industrial Networks, SLU

Secondly, having the option of automatically discovering all the elements in a communication network is not always good. Yes, we are thinking about security issues. It is more and more common nowadays that IT managers dislike solutions that imply identifying devices connected to a network or that provide public information about their status, the information they are working with and the control over third party elements.

Therefore, it is very important in such cases to have the option to determine clearly who is who, and who is doing what.

Here we also have different solutions that BACnet provides: BACnet passwords, priorities and the new BACnet Secure Connect (BACnet/SC), which

solves many networking and security scenarios, such as static IP or broadcasting issues.

What's Next?

We are constantly evolving and improving our products and solutions. We have seen that having the option of automatically finding devices and their objects and properties can save integrators a lot of time as well as help them troubleshoot their projects and installations easily. So, what do we expect next? The deployment of BACnet/SC, usage of Artificial Intelligence (AI), improvements on Internet of Things (IoT) and Industrial Internet of Things (IIoT) are offering a wide horizon of new possibilities to ensure even faster, more secure and reliable integrations in and with BACnet.

ABOUT THE AUTHOR

Pere Mindan is a Senior Product Manager at HMS, dedicated to Intesis OEM solutions and MAPS for more than 8 years, offering support and bringing solutions for Home & Building Automation, HVAC, BMS and IoT customers worldwide. communication.products.



Pere Quim Mindan Seuba
Product Manager Intesis – HMS Industrial Networks
Pese@hms-networks.com | www.intesis.com



Using BACnet and Active Front End VFDs to Lower Your Utility Bill

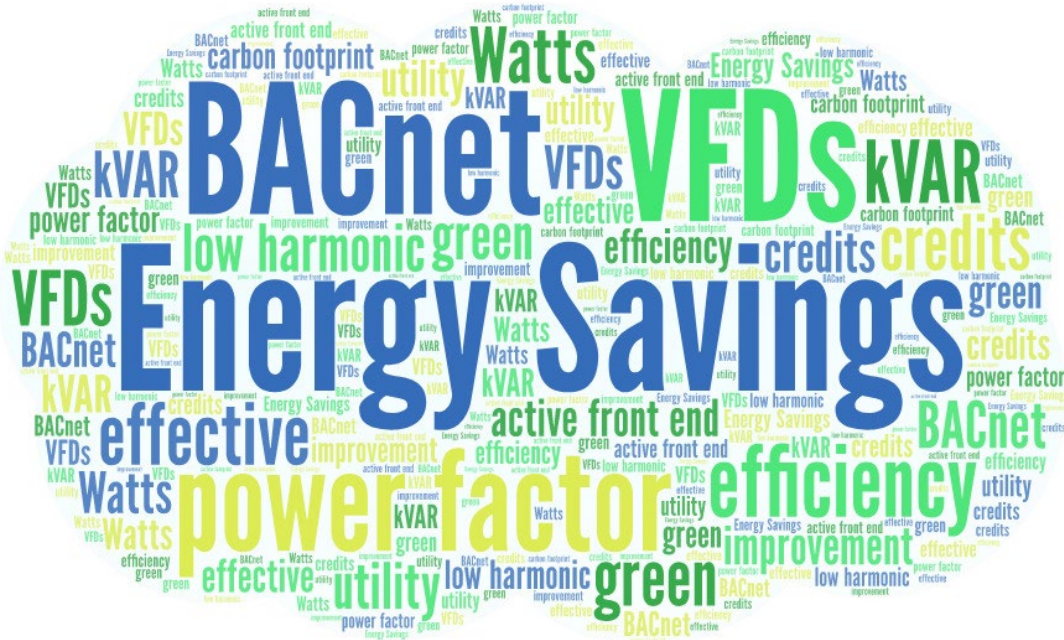

For building owners and chief engineers, when is the last time you really looked closely at the electric bills for your facilities? Perhaps you look at the total bill, but do you look at the details to see if you are being charged a power factor penalty? If you are simply having accounting pay the bill every month, this is a good time to pull out your most recent bill and take a closer look. For consulting engineers, you are naturally trying to design an energy efficient facility, but are you trying to optimize power factor for your client? This article will provide a trick on how to utilize a certain type of variable frequency drive (VFD) along with BACnet to get “free” power factor correction.

What is Power Factor?

Power factor is a way to measure how effectively a facility is consuming power from the utility. A power factor of 1.0 is considered perfect (unity). Power (aka apparent power) itself is made up of real power (kW) and reactive power (kVAR). Certain types of loads result in excessive reactive power, which is a type of power that the utility doesn’t like because often it is not set up to directly bill for reactive power, even though it has to provide reactive power. Thus, the utility uses power factor as a way to bill for kVAR. As you can see from the equation below, as kVAR goes up, the power factor goes down.

$$\text{Power Factor} = \frac{kW}{\sqrt{kW^2 + kVAR^2}}$$

Why Improve Power Factor?

Everyone naturally wants to have an efficient building that effectively consumes power. Lower operating costs and green initiatives are two driving factors. A less efficient building that consumes power in a less effective way will have higher utility bills and a greater carbon footprint than a more efficient building that effectively consumes power. Did you notice that efficient and effective were broken out in the previous sentences? The efficient aspect impacts your kW while the effective aspect is your power factor (includes kVAR). Both of these items are important when considering cost and carbon footprint. Even if a facility has a poor power factor and its utility chooses not to penalize poor power factor, the resulting carbon footprint is still greater, as the utility has to generate extra apparent power for that facility.

Financial Impact

Once the power factor drops below a certain threshold, many utilities will start charging their customers a power factor penalty on their bills.

But, on the other hand, some utilities will reward customers for really good power factor and provide them with a credit. The exact threshold of where power factor penalties kick in, or where rewards are offered, varies based on the local utility. Reach out to your local utility to see how it handles power factor penalties and credits. As a reference point, power factor values greater than 0.95 are often considered good, while values less than 0.85 are considered bad.

How to Improve Power Factor?

There are a variety of well documented approaches to correcting power factor, such as adding power factor correction hardware. There are also some very savvy tricks that are less documented to help improve power factor, and BACnet plays a key role.

Let’s focus on electric motors. As an example, three phase induction motors fed directly from the utility have a negative impact on power factor. Adding a VFD to the motor immediately improves the power factor and brings that load’s power factor from about 0.85 (motor) to 0.92 (VFD). This is a well-known first step, thus we have not reached “savvy” status yet. The next step is to use a low harmonic VFD instead of a standard VFD. Low harmonic VFDs have an even better power factor and some can achieve a per-

fect 1.0 power factor. Now we are getting closer to “savvy” but we are not quite there yet. There are different types of low harmonic VFDs. Some low harmonic VFDs have active front ends which allow them to adjust their own power factor to a leading power factor, or in other words, provide negative kVAR. If you have one of these VFDs, and it is connected to a building management system (BMS) or power management system over BACnet, now is the time to get savvy!

Let's Get Savvy

There is an industry trend to have the BMS monitor a facility's power meter, which includes power factor information. There are active front end VFDs available that can have their power factor adjusted over BACnet. These VFDs can add negative kVAR to offset some of the facility's existing positive kVAR. As previously shown in the power factor equation, as the total kVAR is reduced, the facility's power factor improves. As the characteristics of the facility's load changes over the day, the BMS can monitor the power factor and use the active front end VFD to compensate in real time.

Beauty of BACnet

Most building management systems, and some power management systems, use BACnet communications. BACnet is an open protocol, thus it allows any BMS manufacturer to talk to any HVAC VFD that supports BACnet. With BACnet, you don't get locked into a specific brand or manufacturer of a product.

Summary

Many utilities charge a power factor penalty, or offer a credit, based on a facility's power factor. A BMS can monitor a facility's power factor. The BMS can integrate with active front end drives, over BACnet, and have that VFD compensate and provide additional power factor correction. This solution often comes with no hardware cost increases if the BMS, BACnet, and active front end VFD were already part of the initial design. The only cost impact is the one-time integration cost by the controls contractor. Removing a power factor penalty, or adding a credit, more than offsets that initial cost. 🌱

ABOUT THE AUTHOR

Tim Skell, HVAC Application Engineering Manager at ABB, has been working with variable frequency drives (VFDs) in the HVAC industry for over 15 years. He is also active in the BACnet community and has received a past BACnet Member of the Year award.



Tim Skell
HVAC Application Engineering Manager | ABB Inc
tim.r.skell@us.abb.com | new.abb.com/drives
www.linkedin.com/in/tim-skell/

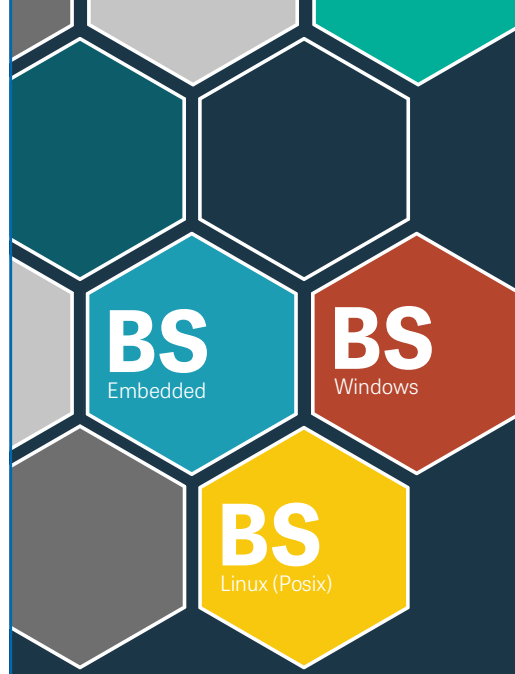

**NEW
UPDATE**

BACnet stack now supports Revision 22 including SC

For optimum security in building automation

The innovative security infrastructure Secure Connect (SC) of cross-manufacturer communication standard BACnet is now supported by the BACnet stack.

Anyone thinking about bringing devices or software packages for building automation to market on the basis of BACnet must decide whether or not they should develop the network protocol themselves or opt for a software stack instead. The stacks from CS-Lab as well as our services take the pressure off both manufacturers and developers alike, who need to implement the communication standard, and this makes their work a whole lot easier.

BACnet stack: Your stress-free path into the BACnet world.



Revision 22



BACnet/SC

www.bacnet-stack.com

Deploying and Maintaining BACnet Systems in Today's Networks

HVAC has made long strides from the days of pneumatic controls to Direct Digital Controls (DDC). DDC systems allow for more precise control of the equipment and processes, leading to greater efficiency. These DDC systems can be networked together over a communication protocol evolving into a Building Automation System (BAS). The Building Automation Systems of today utilize various protocols, such as Modbus, LonWorks, and KNX, but BACnet is the most popular protocol utilized in HVAC/R control systems. There are multiple vendors that support this open protocol which provides a robust ecosystem of devices to choose from. Gateways are available to integrate other protocols to BACnet. BACnet supports communication over multiple transport layers, such as RS-485 interface with BACnet MS/TP, an Ethernet interface with BACnet/IP and BACnet over Ethernet, and more recently BACnet/SC. This article will explore some of the best practices to keep in mind while deploying BACnet. There are considerations which include choosing between MS/TP and Ethernet, size of networks, number of devices, integration with existing IT infrastructure, future expansion capability, and cost. A one-size-fits-all approach cannot be utilized anymore with these networked systems, and the contractor,

systems integrator and building owner must all work in tandem to choose the best option based on their requirements.

BACnet MS/TP Networks

Over a decade ago, MS/TP networks dominated building automation, and IP networks were rare. MS/TP provided longer cable distances, devices could be daisy chained over a bus, and MS/TP cables were cheaper than Ethernet cables. This allowed the MS/TP devices to be kept separate from the IP network traffic, but they could be easily integrated into a BACnet Supervisory Controller directly or by using a BACnet router. MS/TP networks specify a maximum load of 32 devices on the bus. However, with half or quarter load RS-485 transceivers, more devices can operate over the same segment. BACnet MS/TP can support up to 128 MS/TP master devices that participate in the token passing using MAC addresses from 0 to 127. The more the number of devices in the segment, the longer it will take for the token passing to occur on the bus leading to slower communication. In practice, 32-64 devices in a MS/TP segment are suggested for optimal communication. Using BACnet routers offers a low-cost option for segmenting MS/TP networks.

Specifying the MS/TP device MAC addresses in a consecutive range also eliminates polling for non-existing MS/TP master devices. The MS/TP devices provide a setting called Max Masters to indicate the highest MAC address on the bus. The default value of 127 should be changed to the actual highest MS/TP MAC for fastest communication. But if some additional MS/TP devices are planned to be added later to the segment, the Max Masters should be incremented to allow for that expansion. A common issue while adding MS/TP devices is having a Max Masters value lower than the MS/TP MAC of the new device thereby preventing it from receiving the MS/TP token and participating in communication. Today, MS/TP networks remain popular, providing communication to field devices with supervision from high performance BACnet/IP headends. Multiple BACnet routers can be used to integrate the MS/TP segments back to IP networks. Usually the MS/TP devices utilize less powerful CPUs, and BACnet routers can also provide additional features to separate the MS/TP segment from extra BACnet traffic. For example, blocking broadcast I-AM messages if there are only MS/TP end devices on the MS/TP segment saves valuable CPU resources, especially in a large network. Having a smaller MS/TP segment helps isolate a problem to that specific segment because one bad MS/TP device can impact the performance of all devices on that segment.

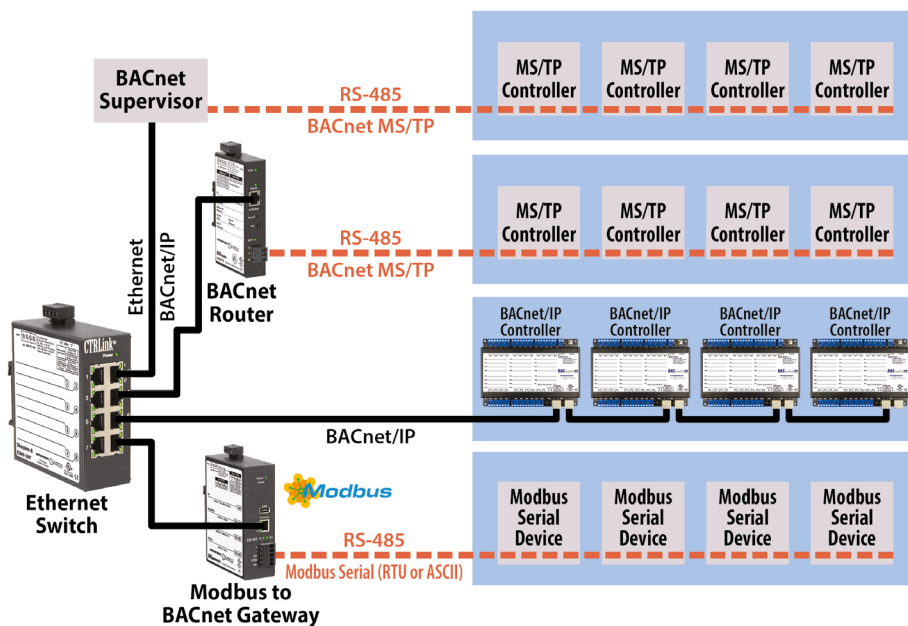

MS/TP MAC	1
MS/TP Network	221
Max Masters	127
Max Info Frames	100
MS/TP Baudrate	76800
MS/TP Tolerance	<input type="radio"/> Strict <input checked="" type="radio"/> Lenient

Tune MS/TP Settings for faster communication
© Contemporary Controls

Flexible Architecture with BACnet/IP and BACnet/MSTP
© Contemporary Controls



Does your VFD utilize BACnet to improve your building's power factor while also providing a free power meter? Ours does.

ABB ACH580 ultra-low harmonic (ULH) HVAC drives support BACnet MS/TP (embedded) and BACnet/IP (plug-in card). The active front end technology enables more data and control from the input side of the drive, allowing input power metering information and power factor correction control via BACnet. The power metering reduces the need for costly separate sub-metering within your building and the power factor correction can reduce your utility bill.

Leverage more data from your drive with BTL listed ABB ACH580 ultra-low harmonic drives on BACnet.

new.abb.com/drives/segments/hvac
new.abb.com/drives/harmonics



BACnet/IP in IT Infrastructure

Today, BACnet networks share IP infrastructure with business networks, high-speed cameras, and IP routers. The result is an immense amount of IP traffic, unrelated to BACnet, impacting the throughput of BACnet networks. The best way to handle the congestion is to restrict communication to only those devices that must be part of the BACnet communication. The use of IP protocol with BACnet/IP lends well to the use of IT best practices to manage the traffic and provide security for BACnet networks. One technique available in TCP/IP routers to restrict the communication is the use of Allowlist to only accept traffic from specific BACnet devices. The Allowlist feature can restrict BACnet/IP traffic to only the BACnet headends and supervisors specified in the Allowlist, thereby providing additional security, and eliminating the devices' need to respond to unrelated messages. Additional options include segmenting networks either by restricting the number of devices in an IP subnet with the use of IP routers or separating them logically with the use of Virtual Local Area Networks (VLANs). This again leads to a choice between using low-cost, unmanaged Ethernet switches to connect the Ethernet segments with plug-and-play operation or using managed Ethernet switches that provide features such as VLAN, fault detection, SNMP for traffic count, and redundancy with Rapid Spanning Tree protocol (RSTP).

Managed Ethernet Switches – Redundancy and VLANs

RSTP is an IEEE protocol that has been used to provide cable redundancy in Ethernet networks. Quite a few IP controllers and rooftop units (RTUs) and air handling units (AHUs) have two Ethernet ports to daisy-chain devices for easy wiring. An issue with daisy-chaining devices that impacts both MS/TP and IP devices is that a cable break renders the devices after the break unreachable. By using RSTP, the IP devices can be wired in a ring topology where the protocol keeps one Ethernet port in blocking state to prevent a communication loop. If a cable break occurs, the backup port is enabled allowing the communication to continue. The maximum number of devices in an RSTP ring is 40. This warrants the use of Managed Ethernet switches and all other devices to support and have the RSTP protocol enabled. A common issue seen is mixing unmanaged Ethernet switches to save cost by justifying that the cable break at the segment will not occur, thereby jeopardizing the whole setup. Another issue is having two RSTP rings conform to the size of 40 devices going

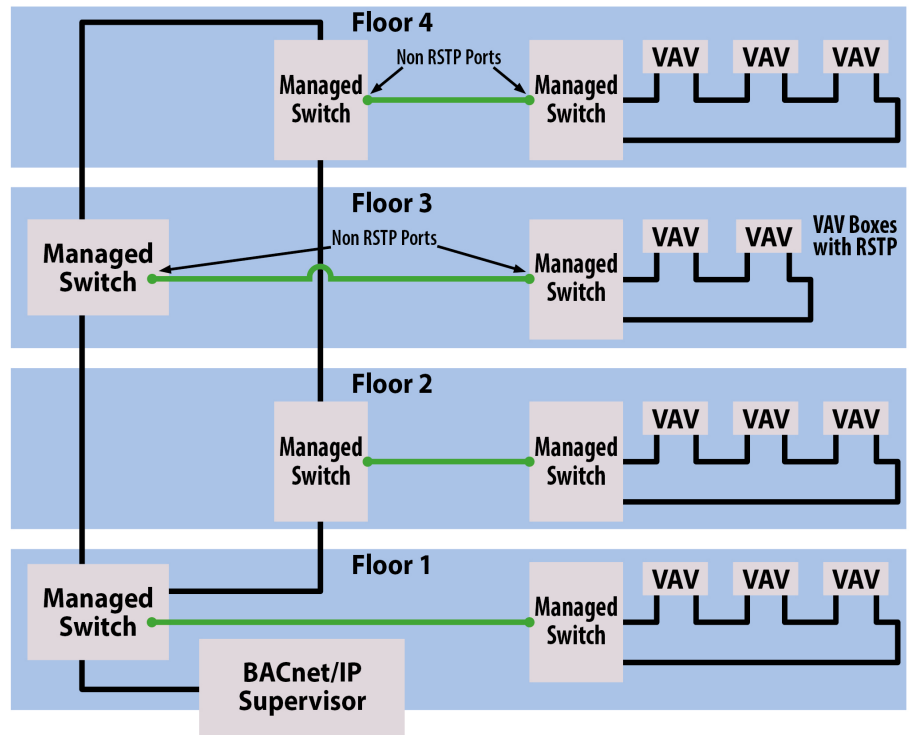

Redundant topology with Managed Ethernet Switches and VAVs using RSTP
© Contemporary Controls

back to the same managed switch backbone. A break in these two rings will lead to the violation and exceed the 40-device limit in the RSTP segment. It is advisable to use a separate backbone of Managed Ethernet switches with RSTP and then have another managed switch that provides an RSTP segment for the AHUs/RTUs. The RSTP protocol on the Ethernet ports connecting this managed switch for AHUs to the main RSTP backbone Ethernet switch should be disabled. To prevent communication loss due to a power failure, some dual Ethernet port devices utilize an internal relay to bridge the two Ethernet ports together, effectively incrementing the Ethernet segment length. The stipulation for maximum Ethernet segment length of 100 m still applies, and care must be taken not to exceed this distance when the device loses power.

Managed Ethernet switches also provide the VLAN feature to keep groups of devices in logical partitions even though the same physical Ethernet cable carries the traffic. This can be useful to keep the high traffic IP cameras separate from the BMS system. A 10-year-old BMS system may not be able to keep up with the high multicast traffic from the cameras, while new BACnet/IP controllers with powerful CPUs will work fine in the same network. Using managed switches with VLANs provides a secure and easy way to prolong the life of the BMS systems.

Network Sizing and Limiting Traffic using IP Routers

Segmenting using IP routers also provides a convenient way to manage and later expand IP networks. It may seem easy to have a flat network for all the devices, but then all the devices are inundated with the extra broadcast and multicast traffic on this single subnet. The IP routers keep the broadcast and multicast traffic constrained to their own IP subnets. A few years ago, a single bad Ethernet card was blamed for bringing down an airline system at an airport. This is analogous to having a big warehouse with an open office where all departments and personnel are trying to communicate over one another versus subdividing that office space into different sections and rooms. BACnet communication relies on the use of broadcast messages for device discovery, but a BACnet/IP Broadcast Management Device (BBMD) can easily be used to facilitate BACnet communication across subnets. Almost all the BACnet/IP to MS/TP routers provide BBMD functionality, though the support of the number of BBMDs/subnets may vary. Vendors may have different models to support different network sizes. A gas station with a few devices needs to be designed differently than a high-rise office building. Care must be taken not to create a BACnet loop by improper duplicate BBMD entries.

IP routers also facilitate the integration of BACnet devices in the existing IT infrastructure. The IT personnel only need to assign one IP address for the WAN port of the IP router, and all the BACnet devices can form their own network on the LAN subnet with an independent IP address scheme. Compare this to getting IP addresses for each device that must be integrated. The IT department may still need to know some information regarding the devices being added to the BMS system but will surely appreciate the option of not handing out additional IP addresses. We explored how to separate BACnet devices from extra traffic within business networks, but the reverse is also true. The IP routers also prevent the BACnet traffic from reaching the business system network. Additional IP router features, such as VPN, provide remote access for diagnostics and troubleshooting.

The BMS systems are installed for comfort, occupant safety, as well as energy savings. Many times, a BMS system must be changed when the building owner wants to change maintenance contractors, but the owner later finds out that he only has the login credentials for viewing the display graphics and doesn't have the administrative credentials to make additional changes. Having access to the administrative credentials for the BMS system is a must for building owners. The advent of security in BACnet with BACnet/SC and the push towards IP networks in general for BACnet will warrant a closer collaboration between HVAC and IT departments, and it is imperative that basic knowledge regarding IP networks be part of companies' training plans for their personnel.

ABOUT THE AUTHOR

Harpartap Parmar is a Senior Product Manager at Contemporary Controls, which designs and manufactures BACnet building controls and networking equipment. Parmar focuses on network security, IP routers and their application to Building Automation. He has more than 21 years of experience at Contemporary Controls developing and testing a range of networking, control and communication products.



© Parmar

Harpartap Parmar
 Senior Product Manager | Contemporary Controls
 hparmar@ccontrols.com | www.ccontrols.com



FieldVEU

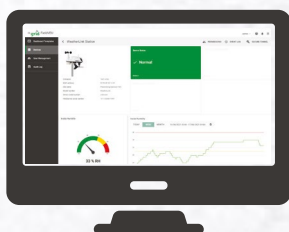

MSA Safety Grid



FieldServer



Controller



Introducing FieldVEU - Cloud Dashboards for MSA FieldServer

The new FieldVEU consists of cloud-based dashboards for MSA FieldServer.

These subscription-based dashboards include user-friendly features such as:

- The ability to customized dashboards
- Ease to which device's data is connected to widgets
- Users get their device notifications via E-Mail and/or SMS



For more information, visit <https://us.msasafety.com/FieldVEU>

Hong Kong Road to Smart City Passes Through Massive Data Integration



Electrical and Mechanical Services Department (EMSD) of the Hong Kong Special Administrative Region (HKSAR)
© HKSAR

Building Portfolio

The Electrical and Mechanical Services Department (EMSD) of the Hong Kong Special Administrative Region (HKSAR) manages E&M facilities for government venues in Hong Kong. Among the venues, over 400 have an annual electricity consumption of 500,000 kWh and above. In possession of the huge amount of building operational and energy data from a wide range of systems, EMSD started to develop an integrated Building Management System (iBMS) on an unprecedented scale. As expected, the buildings are of various ages and equipment conditions. Thus, in the beginning of the project, iBMS guidelines and specifications were formulated to standardize the data collection requirements. A checklist was developed for standard project submission mandating BTL certificates and PIC statements for newly installed products to assure quality and conformance in fulfilling the iBMS connection. In 2019, EMSD set up its first iBMS platform at the Headquarters, integrating operational data from widely dispersed buildings at the city level. Targeted buildings were prioritized based on their electricity consumption and readiness for connection. The platform offered opportunities to enhance system reliability to enable benchmarking and linking up with big data analysis with an aim to achieve a better building performance. This project improved the building data structure which rendered support to Hong Kong towards a smart city.

Familiarizing Problems

Several unique problems were encountered during the course of development. With the increasing age of a building, there often appears different degrees of inconsistencies on BMS settings due to past retrofits and deterioration of the existing system. In some buildings, communication through BACnet might not have been possible because of the use of a proprietary protocol. Interoperability became a critical issue for a successful integration. Meanwhile, the iBMS network architecture required continuous review to accommodate the quick expansion of the system when more buildings were being connected. The method to establish a remote BACnet network was another challenge. The experience in our first trial of applying Foreign Device Registration (FDR) for the connection to the central iBMS workstation raised troubles on the manual update of the network address when testing with third party protocol analyzers. This hindered future migration to any new system platform. Since iBMS data was built up through direct communication with BACnet devices at the venue level, the variety of object naming conventions and trend log/alarm settings at each venue would impair the quality and the application of iBMS. Another challenge in this project was the requirement to export iBMS data to our Regional Digital Control Centre (RDCC), which consisted of an in-house developed data server for further machine learning and Artificial Intelligence (AI) applications.

Collaborative Working

Making iBMS a sustainable solution to the department, EMSD took advantage of the vendor neutral environment under BACnet in 2020 to engage the current system integrator to review the iBMS architecture and carry out server upgrades to cope with the continuing expansion. Enhancement included making available a BACnet router with the Network Address Translation (NAT) function at the venue level such that all BACnet devices resided on the same IP subnet i.e. virtual devices at venues could share the building data with the iBMS platform located at the Headquarters under the same IP network. Despite the data scope not covering sensitive information, security on data transmission was always a primary concern, especially for critical government venues delivering essential public services. To achieve a secured converged network, a Virtual Private Network (VPN) configuration was used to ensure cyber security. The use of a dedicated VPN IPsec tunnel allowed for the segregation of venues per owner basis which further enhanced data privacy. The cyber security of the iBMS system architecture was further proven upon satisfactory testing through a Security Risk Assessment and Audit (SRAA) in accordance with the government IT security policy. An independent Certified Information System Auditor was appointed and it was concluded that the connection method could be similarly applied for future venues. The abuse of a vendor's proprietary properties led to the absence of meaningful representation of a data object when communicating with other vendors' BACnet devices, which could ruin the iBMS system quality. To resolve these issues, engagement of the front-line staff who performed daily operation and maintenance of the BMS at the venues was crucial to the success. Site visits were conducted to enhance colleagues' understanding of how to implement necessary modifications on the BMS for a better iBMS. The iBMS team also convened meetings and workshops to collaborate with key players in this project to promote the importance of BACnet compliance. As a baseline, BACnet standardized data structures shall be strictly followed. Other requirements include (a) object name should be properly defined according to the point abbreviation presented in the iBMS guidelines, (b) simple number assignment with cross reference to proprietary filed

should be avoided, (c) other than input/output (I/O) objects, all software points are required to be BACnet compatible to achieve full compatibility, and (d) for venues with genuine difficulties, new dedicated building controllers for iBMS might be considered to ensure object properties, including naming convention, alarm and trending, are properly set.

Successful Outcome

Through the learning process in this project, the department is now able to attain the optimized iBMS configuration which best adapts future changes on any equipment replacement or alteration works. iBMS provides handy access to essential operating information on a unified platform for everybody's use. A common Graphic User Interface (GUI) was developed to reduce misunderstanding by adopting same choices of words and graphic icons, i.e. a common look and feel. The standard graphical presentation enables sharing of information across buildings with minimal difficulty. To further enhance the user experience, LDAP user authentication was arranged for centralized login for colleagues in EMSD which eliminated the need for regular updating due to staff movement. In this project, we established a database connection at the server level with the data lake under RDCC to enable data exchange automatically by schedule. Data cleansing and validation were then performed before proceeding to big data analysis and AI application by RDCC. With sufficiently large volumes of data, it is now possible to perform benchmarking with minimal efforts, find ways to improve energy efficiency, and enhance daily operational routines and system optimization. Real time data and alarm notification with RDCC has been tested and proven to be achievable through RESTful Web Service Interface following ASHRAE 135-2016 Annex W. This enables machine learning from historical and real time data to analyze failure patterns which assist in the development predictive maintenance tools. With the solid foundation of the iBMS platform, EMSD will connect more venues to the iBMS and the system is expected to double by 2023.



EMSD Interior 2

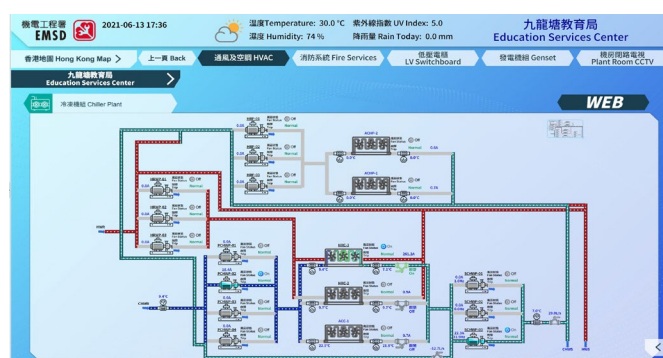

EMSD KTESC chiller

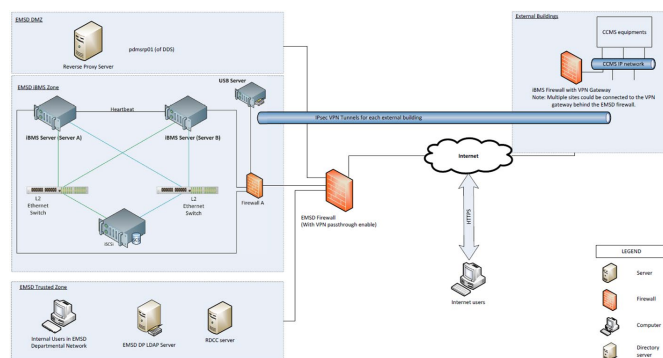

EMSD System architecture

機電工程署
EMSD

Electrical and Mechanical Service Department
info@emsd.gov.hk | www.emsd.gov.hk/en/home/index.html

Hensen System Engineering Ltd.
info@hensen.com.hk | www.hensen.com.hk

Energy Management at the Empire State Building



\$800,000 annual energy savings at the Empire State Building

Long before data analytics was the hot topic it is now, the industry was developing and applying software and analytics to highly underutilized data streams. With a proven track record of dramatically improving how buildings operate, energy management analytics helped the iconic Empire State Building team save \$800,000 annually in budget-eating energy costs.

Problem

It's a fact. Energy use is the single largest operating expense in commercial office buildings, accounting for about one-third of a typical operating budget. Reducing HVAC costs is an imperative for building owners; however, it begs the question: How do you get HVAC costs under control while balancing the comfort of occupants?

The answer lies in the data that can be found within the devices and sensors of a BACnet-controlled HVAC system.

With the Empire State Building, building owners monitored the astronomical energy usage and

needed to look to an energy management company to help in reducing energy costs. But, because that important BACnet data is stored within the devices

and sensors (and out of normal reach of the building's owners) there was a definitive need for a cloud-based software analytics solution.

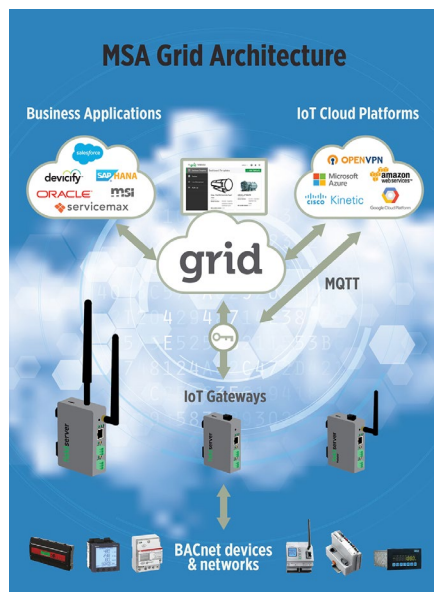

The MSA FieldServer BACnet IoT Gateway is a plug-and-play solution that quickly and easily integrates with BACnet Networks. © MSA Safety

The solution absolutely, positively would need to enable the harvesting and analysis of BACnet data, giving the building's owners/property managers actionable insights. These insights, in turn, would allow them to dramatically cut energy usage of their HVAC systems and devices without sacrificing tenant satisfaction.

For an energy management cloud solution to deliver the requisite real-time operating insights, the platform needed to connect directly to the BACnet network and acquire the required device and temperature data. With advanced technologies, this is not a problem – unless the solution cannot automatically identify the appropriate point names, which contain the necessary data.

This causes a disruption in data flow, which most often happens due to the lack of standardized naming conventions; not to mention the fact that many facilities have not implemented data tagging.

Unless and until the data is extracted from each BACnet-compliant controller, component, or system for analysis and interpretation, the data will literally just sit there, yielding nothing. What is needed to access that data is a gateway that facilitates exploration of the BACnet network.

Solution

For the Empire State Building, the solution was the plug-and-play BACnet IoT Gateway solution. It immediately solved the problem by providing the ability to explore the BACnet environment. Energy managers could select the needed energy BACnet objects for publishing to a cloud-based energy management system. Then the data analytics engines could crunch the numbers that would

inform energy management policies and, ultimately, reduce energy consumption.

For the owners of this iconic building, the benefit of using a third-party application for energy management (besides a BMS system that it specifically focused on building automation) was clear: Data scientists can continually update the algorithms and further improve the efficiency of heating and cooling of the building.

But that's not all. Data security, which is a concern for cloud-based energy management systems, also was addressed by the gateway solution. Both the gateway and the cloud are rigorously penetration tested and certified secure. That means they meet the industry's stringent cybersecurity requirements.

The beauty of the described solution is that it's not exclusive to the Empire State Building. Other buildings can and have been exposed to energy management cloud solutions, giving energy experts the ability to quickly find the relevant BACnet data, run their algorithms, implement strategies to achieve energy-efficient buildings, and potentially – and substantially – reduce building energy costs. 🌱



MSA Safety
 info.us@msasafety.com
 www.msasafety.com

Building on BACnet



Contemporary Controls is a proud supporter of BACnet and other open control concepts. BASautomation products offers open solutions for implementing networked controls in buildings. With over 45 years of networking experience, locations around the world, and a reputation for technical support, Contemporary Controls has the expertise required to make your building automation projects successful.



Learn more at www.ccontrols.com/bas

Bergwelt Grindelwald: Rustic Chalet Charm Meets High-Tech Room Automation



The main complex fits harmoniously into the village of Grindelwald. © HRS Real Estate AG

Grindelwald lies in a valley on the northern side of the Alps, within a scenic panorama boasting the famous Eiger, Mönch and Jungfrau mountains. The village below the north face of the Eiger has been a tourist magnet for generations.

This year there's a new place to stay in the village: Bergwelt Grindelwald. The apartment hotel marries modern design furnishings with the rustic charm of the Bernese Oberland. It has plenty more to offer behind its façade too. A spa area (800 m²) and outdoor and indoor pools will relax the body and soul, while the cigar lounge and bar present the perfect backdrop for conversation. At "BG's Grill", dishes are served on a stone slab, brought directly from the open charcoal grill. And if you like, you can even go straight to the fitness centre and work off that hearty Swiss cuisine!

At the centre of the complex of chalets and condos is the hotel with more than 90 rooms. In winter, sports enthusiasts can jump on their skis

and take to the slopes in a flash. In summer and autumn, it forms the ideal springboard for hiking through crevasses or exploring the magic of the Jungfrau region.

Room automation with SAUTER components throughout

HRS Real Estate AG, the resort's constructors, already knew from previous collaborations the value of SAUTER expertise. As it optimised the individual room regulation concept originally tendered, SAUTER proposed a dovetailed automation solution using single-source technology. This cut the resources needed by an impressive 20%, proving to both customer and specialist planners that SAUTER indeed had the ideal solution.

From the building management system, automation level, individual room control right through to the field devices: the rooms and HVAC installa-

tions at Bergwelt Grindelwald are equipped with SAUTER components. The original tender consisted of Modbus intelligent unitary control. The enhanced concept, however, provides SAUTER modulo system-based automation with native BACnet support. It not only monitors room climate but the window contacts and card readers as well. The modular room automation stations at Bergwelt Grindelwald take the shape of ecos504 room controllers, their powerful function modules minimising energy use. ecoUnit room operating units enable individual adjustment of room climates. Energy meters are system-integrated via M-Bus. A specialist planner will always be on hand to continuously optimise energy consumption.

SAUTER Vision Center is deployed for building management at Bergwelt Grindelwald. Countless features such as customised dashboards and user-specific evaluations provide key information at a glance.

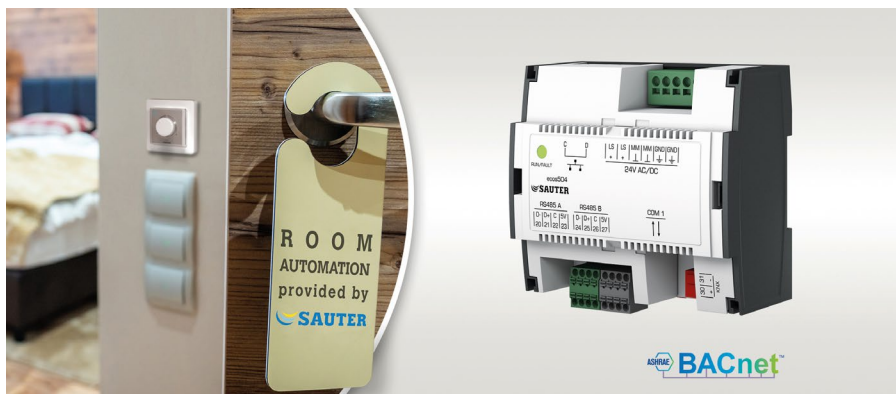

SAUTER ecos504 room automation stations (right) and SAUTER ecoUnit room control units are used for room automation at the Bergwelt Grindelwald. © Fr. Sauter AG

111 years of SAUTER

This project is not the only reason why Grindelwald has a special meaning for SAUTER. The company was founded here no less, 111 years ago. In 1910, Fritz Sauter opened a small workshop in a barn where he developed timers. Back then, his inventions helped increase the efficiency of boilers and street lamps. While his company's product portfolio has constantly evolved over the years, SAUTER has remained true to the original idea – efficiency. 🌱



SAUTER Schweiz

werner.freitag@ch.sauter-bc.com | www.sauter-building-control.ch

New Chairman of ASHRAE SSPC 135: Coleman Brumley

Coleman Brumley is Software Engineering Manager and IoT Evangelist for Setra Systems, Inc. He currently serves as Chair and voting member of ASHRAE SSPC-135, taking over the position from Mike Osborne, whose term ended on 1-July-21. During his 20-year involvement with the committee, Brumley served as Secretary for 3 years followed by Vice Chair for 3 years, and several terms as a voting member. In addition, Brumley served as convener of various working groups, starting with the IP-WG in 2010 followed by its successor, the PS-WG, starting in 2015.

Brumley is a widely recognized BACnet speaker, teacher, and contributor in multiple BACnet forums. He was the recipient of the prestigious 2015 Swan Award as well as the recipient of the 2015 BACnet International Leader of the Pack St. Bernard Award. Brumley holds a Bachelors Degree in Computer Science from West Virginia University as well as an Associates Degree in Business Administration from Penn State University.



Brumley lives in Greensburg, PA with his wife. They have two adult children and one grandson. In his free time, Brumley is an avid do it yourselfer and enjoys traveling with his wife.

Goals/Thoughts

With the ongoing exponential growth of IoT technology, it's important that BACnet remain relevant. In the next 3 years, I hope to see continued development of secure, yet interoperable, ways for BACnet to integrate with these new technologies, including new low power wireless technologies.

I'm looking forward to continuing the good work with BIG-EU, which was started by my predecessors.

Interesting Notes

My first exposure to the BACnet committee was through the BTL Interoperability Workshop (aka "PlugFest") where I was introduced to Bill Swan. After an interesting discussion with Bill about BACnet, he suggested that I should participate in committee meetings. I've been hooked ever since! 🌱

New to the BACnet International Family



BACnet International is the global organization that encourages the successful application of BACnet through interoperability testing, educational programs and promotional activities. BACnet International complements the work of other BACnet-related groups whose charters limit their commercial activities.

BACnet International community membership includes a who's who list of top tier companies and industry professionals involved in the design, manufacture, installation, commission and maintenance of control and other equipment that use BACnet for communication.

We are proud to welcome the following new members to BACnet International.

New Gold

TERMINUS 特斯联

Terminus Technologies Group

Terminus Technology Group Co., Ltd. is the core strategic platform of China Everbright Limited in the 'new economy' sector. Terminus is the first enterprise to coin the term – AIoT (Artificial Intelligence + Internet of Things), and to apply AIoT technical architecture in China. It is committed to becoming the world's leading 'City OS' platform corporation. In July 2020, Terminus became the Official Premier Partner of the Expo 2020 Dubai.

11F, West Tower, Genesis Beijing
South Xinyuan Road
Chaoyang District, Beijing, China
www.ts-smart.com

New Silver



Envision Digital

Envision Digital is focused on bringing technology solutions to the sustainability challenge. Its world-class AIoT technology helps governments and companies across the world accelerate progress toward a net zero future and improve their citizens' quality of life. Having established itself as a leading solutions provider for intelligent renewable energy generation, consumption efficiency and smart flexible storage, it has extended its capabilities beyond energy to enable and optimize applications notably in smart cities, smart buildings and estates, smart infrastructures, e-mobility and smart plants.

1 Harbourfront Avenue
Keppel Bay Tower #17-01
Singapore 098632
www.envision-digital.com



NETxAutomation Software GmbH

NETxAutomation Software GmbH is one of the leading providers of innovative software for building automation. They develop and distribute software for building management and central building control. Their product range consists of reliable server systems, shading control systems, visualizations, energy reporting systems and hardware components. In more than 100 countries all over the world, system integrators and electrical engineers use their software in their building automation projects.

Maria Theresia Strasse 41
4600 Wels, Austria
www.netxautomation.com/netx/en

Upgraded Silver to Gold



Control Solutions Inc.

Control Solutions, Inc., a Minnesota corporation founded in 1995, offers a line of control products tailored to facility management, building automation, telecommunications, and remote monitoring & control. Control Solutions has thrived on opportunities to expand, enhance, and support mainstream products and systems. As a result, you can find a little bit of their equipment connected to a lot of other people's equipment, in a lot of different places, doing a lot of different things.

10550 South Avenue
PO Box 10789
Chisago City, MN 55013, United States
www.csimn.com



Shanghai Sunfull Automation Co., LTD

Shanghai Sunfull Automation Co., LTD is a leading manufacturer in China. They are devoted to gateway products research and development in the fields of building control, industrial control, transportation, air conditioning and refrigeration, coal mine, water supply, energy, power, and more. They take the lead in applying HTML5 SVG, Web-Socket specification and AJAX technology to the gateway, to allow the use of mobile phones, iPad and other intelligent terminals to monitor real-time data on the browser through the gateway.

A466, NO. 2588, Jinhai Road, Pudong
Shanghai, 201209, China
www.bacnetchina.com

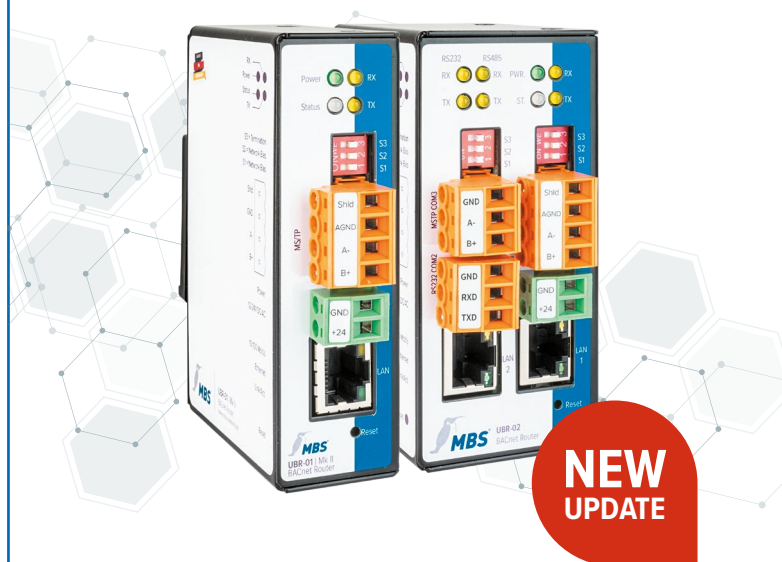

Universal-BACnet-Router with BACnet Secure Connect

For optimum safety in building automation

The MBS router now contain the current BACnet Revision 22 which, itself, includes standards for establishing secure building automation. They are also backwards compatible meaning that the BACnet equipment already installed in an automation system can communicate with the new Universal-BACnet-router. This ensures both sustainability and investment security. The previous features are still available to ensure that data can still be routed with BACnet MS/TP, BACnet/IP and BACnet Ethernet.

Expand Your BACnet Knowledge!



Courses • Resources • Community

TBI continues to grow. There are now over 6,000 registered users, and articles and presentations are continually being added to the Library section, providing many resources to help you and your colleagues stay connected and engaged. A better-informed community brings positive change, so take a moment to expand your knowledge of BACnet as well as encourage others!

Popular BACnet International Trade Show Session Recordings

BACnet International has presented an Education Track at the past several AHR Expos. These sessions always receive high praise and in 2020 we had record-breaking attendance. Most show sessions were recorded and have been uploaded onto TBI for you to experience either again or for the first time, including the five presented at the 2020 AHR Expo. Those sessions include BACnet 101; BACnet Physical Connectivity; Design Considerations When Applying the BACnet Standard to a 'Smart Building' BAS; BACnet Edge Solutions; and HVAC as a Service.

Multi-Level and Multi-Lingual Resources in the Library

With over 140 articles and presentations focused primarily on BACnet, the TBI library offers a variety of topics, in different languages and expert levels. Among the top articles accessed are "A Brief History of BACnet," "LED Lighting - An Automation Armageddon," "BACnet Physical Connectivity"... and many more. Also check out the bi-lingual "Device Profile Families Facilitate Planning" article by Bernhard Isler. Check back often, since articles continue to be added.

Interactive Courses Fit into Your Schedule, and Offer FREE CEUs!

There are three interactive courses available on TBI, and, as an IACET Accredited Provider, BACnet International offers FREE Continuing Education Units (CEUs) upon completion of each course. Professional Development Hours (PDHs) are also available upon completion. The three courses are:

- **BACnet Basics** - a comprehensive course that covers all the basics of BACnet. Don't know anything about BACnet or need a refresher? This is an excellent course to take.

- The Facility Manager's Guide to Building Automation Systems. You don't need to be a facility manager to take this course, in fact, this course is incredibly beneficial to anyone who works in the building automation industry.
- BACnet Device Profiles - introduces learners to the various BACnet device profiles and explains the role of each in the building automation. It also shows the learner how various profiles can be combined in a single device and explains the rules behind the combinations.



If you haven't visited The BACnet Institute recently, you definitely should! AND, remind your colleagues to do so as well! To access all of these resources, or to sign up for a FREE account, visit www.thebacnetinstitute.org

BTL Testing Updates



BTL Testing and BTL Test Package Information

A BTL Certification indicates that the BACnet Stack of the product has successfully passed rigorous industry standard testing and demonstrates that the device correctly implements all of the BACnet functionality it contains as governed by ASHRAE standard 135.1. The BTL Listing, the BTL Certificate of Conformance, and the right to use the BTL Mark are the three elements that indicate a product has passed the testing and achieved BTL Certification.

The BTL Working Group defines the BTL Test Plan and governs the testing. The BTL Test Package and BTL Testing Policies are published on the BTL website: bacnetlabs.org/test_documentation.

Minimum Protocol Revision Changes January 1, 2022

The BTL Testing Policies states (Section 3): "The BTL requires that products being tested for BTL Certification claim a Protocol_Revision equal to or greater than a moving minimum. The minimum Protocol_Revision is determined each January 1st and is the highest Protocol_Revision which has been available in a BTL Test Plan for at least 4 years."

On January 1, 2022, the minimum Protocol_Revision will become PR_15. This does not apply to unchanged products applying for BTL Certificate Renewal Testing.

Existing BTL Certifications and BTL Listings are not affected. However, if a product is updated and is submitted for re-testing with changed or new BACnet functionality, then the product must be PR_15 or higher.

All products that are at their Recognized BACnet Testing Organization (RBTO) and are **ready to begin testing** before the end of 2021, may test at the current minimum Protocol_Revision (PR_14).



Suppliers can enroll in the program, register their devices, and schedule and attend live test sessions. BRITE is free for BACnet International corporate members throughout 2021. 

For more information, and to enroll in BRITE, visit bacnetinternational.org/brite.

BRITE should not be confused with BTL Testing for BTL Certification.

ABOUT THE AUTHOR

Emily Hayes began work with BACnet International in 2014 as BTL-Coordinator, coordinating BTL Testing at the BTL Lab. In 2017, Emily took over leadership of the BTL Working Group as chair. Additionally, she led the transition from the BTL Listing Program to the BTL Certification Program. She became BTL Manager in January 2019.

Emily maintains professional membership in the Project Management Institute (PMI), North Carolina Chapter of PMI (NCPMI), and Institute of Electrical and Electronics Engineers IEEE.

Emily has a BEE from Auburn University and an MSEE from Duke University. She has maintained a Project Management Professional (PMP) Certification since 2010.

How Clarification Requests and Fix Addenda affect the BTL Test Package

Any BTL Clarification Request Response that affects the applying or results of a test in the BTL Test Package must be applied during BTL Testing. Additionally, Fix Addenda (addenda to fix a problem found in the BTL Test Package) must be applied.

BTL has recently updated the [BTL Documentation page](#) to assist developers and testers in determining which Clarification Request Responses and which Fix Addenda are applicable to their testing. The addenda that must be applied to the BTL Test Package are included in the zip file that is downloaded when selecting the BTL Test Package on the Test Documentation page. The applicable BTL Clarification Request Responses are included in a zip file below the BTL Test Package.

Archived BTL Clarification Request Responses are available at the bottom of the [BTL Test Documentation Page](#). These do not need to be applied to the current BTL Test Package.

BACnet Secure Connect (BACnet/SC) Resources

BACnet/SC Resources Available to the BACnet Community

The BACnet/SC Interoperability Acceleration Program run by BACnet International has completed. The program provided building automation system suppliers with the knowledge and skills necessary to incorporate BACnet/SC in their products and solutions. It also generated a reference implementation and configurable test bench for BACnet/SC.



This BACnet/SC Reference Stack was published on SourceForge in August 2021 and can be found here: sourceforge.net/projects/bacnet-sc-reference-stack/.

As part of the program, BACnet International conducted three educational webinars. These BACnet/SC Webinars were recorded and uploaded to the BACnet International YouTube page in September 2021 and can be found here: youtube.com/c/BACnetInternational.

For additional information on BACnet Secure Connect resources, visit the BACnet International website at bacnetinternational.org/secureconnect.

BRITE Testing Resource

BRITE (BACnet Remote Interoperability Test Environment) provides a confidential, supplier-independent environment for remote interoperability testing of BACnet devices. The focus of BRITE is BACnet Secure Connect product interoperability testing, and it utilizes BACnet/SC to achieve secure connections over the Internet.

BRITE is built around a collection of cloud-based BACnet/SC hubs along with interoperability support and diagnostic tools. Test sessions typically involve two suppliers and are arranged through BACnet International. Each session is private, only allowing access to the specific suppliers participating in that test session.

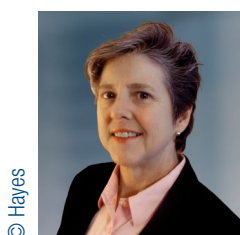

Emily Hayes
BTL Manager, Certifications and Listings
Manager and BTL Working Group Chair
btl-manager@bacnetinternational.org | www.bacnetinternational.org



NEW BTL-LISTED PRODUCTS, August 2020 – August 2021

Manufacturer	Product Name	Model
Computrols	LX	8-LX, 16-LX, 32-LX, 64-LX
Control Solutions, Inc.	Babel Buster	BB3-7301
DAIKIN Industries	D3-NET/BACnet MS/TP Communication adaptor	DTA118A71
Dwyer	Series DHC Digihelic	DHC-xxx-opt where: xxx is pressure range (002, 003, 004, 006, 008, 009, 010, 011, 012, 202, 203, 204, 206, 208, 209, 053, 055, 056, 253, 255, 256, 082, 084, 282, 284) opt is 0 or more of : FC, NIST, COO, SS
Dwyer	Series MSX-Comms Magnesense®, Series MSX Pro-Comms Magnesense®	MSX-x¹x²-x³-COM-OPT where: x¹ is W, U, S, Y, Z or D x² is 10, 11, 12, 13, 14, 20, 21, 22, 23 or 24 x³ is IN, PA or MM OPT is null or more of: LCD, FC, NIST MSXP-x⁴x⁵-x⁶-COM-OPT where: x⁴ is W, U or D x⁵ is 10, 11, 12, 13, 14, 20, 21, 22, 23 or 24 x⁶ is IN, PA or MM OPT is null or more of: LCD, FC, NIST
HERMOS AG	FIS#bacnet	FIS# 2.5
Hubbell Lighting	NX Distributed Intelligence	NX Area Controller
Innotech	Omni BEMS Controller	OMC14, OMC14D, OMC20, OMC20D, OMC40, OMC40D, OMC10, OMC8, OMC10V, OMC8V, OMC40-Q, OMC40D-Q, OMC20-Q, OMC20D-Q, OMC8-Q, OMC10-Q, OMC8V-Q, OMC10V-Q
J2 Innovations	FIN Framework BACnet Operator Workstation	FIN-BACnet-OWS
Kieback&Peter GmbH & Co. KG	DDC4000e	DDC4002e, DDC4020e, DDC4040e, DDC4200e, DDC4400e
Lennox International	Lennox CORE Unit Controller	106519-01
M2S Electronique Ltée	TX-COMMERCIAL-WIFI	TX120-WIFI
M2S Electronique Ltée	TX COMMERCIAL MS/TP	TX070 MS/TP, TX120 MS/TP
MOXA Inc.	MGate 5217 Series	MGate 5217I-600-T, MGate 5217-600-CN, MGate 5217I-1200-T
Paragon Controls Inc.	Multi-Trans Smart Ecosystem – Flow and Pressure Measurement System	MTSE, OAFE-2000
Schneider Electric	Smart Field IO Module	SF-IO-10A-F, SF-IO-12A-F, SF-IO-16A-F, SF-IO-16B-F, SF-IO-20A-F
Siemens	FIN BACnet Connector	FIN 5
Siemens	FS20 Fire Detection System	FC2020, FC2030, FC2040, FC2060, FC2080, FG2020, FT2040, FT2080, FC721, FC722, FC724, FC726, FT724
Siemens	Desigo PX Automation Station	PXC00.D, PXC00-E.D, PXC50.D, PXC50-E.D, PXC100.D, PXC100-E.D, PXC200.D, XC200-E.D, PXC12.D, PXC12-E.D, PXC22.D, PXC22.1.D, PXC22-E.D, PXC22.1-E.D, PXC36.D, PXC36.1.D, PXC36-E.D, PXC36.1-E.D, PXC52, PXC-NRUF, PXC00-U, PXC64-U, PXC128-U, PXC001-E.D, PXC001.D
Sontex SA	SUPERCAL 5I/5S	Module SC5X00021
Tridium	Niagara 4 Supervisor BACnet Advanced Workstation	SUP-0, SUP-1, SUP-2, SUP-3, SUP-10, SUP-100, SUP-UNL

Tridium	Edge 10	14039
Tridium	JACE 8000	12977
WAGO	Controller PFC200	750-8212/0000-0100 750-821x/y where: x is 0, 1, 2, 3, 6 or 7y is null, 0040-0000, 0025-0000, 0025-0001, or 0025-0002

Calendar of BACnet International Events

2022	Event	Location
January 13, 2022	BTL Working Group Meeting	Teleconference
January 27, 2022	BTL Working Group Meeting	Las Vegas, NV
January 31 – February 2, 2022	AHR Expo	Las Vegas, NV
February 10, 2022	BTL Working Group Meeting	Teleconference
February 24, 2022	BTL Working Group Meeting	Teleconference
March 10, 2022	BTL Working Group Meeting	Teleconference
March 24, 2022	BTL Working Group Meeting	Teleconference
April 20 – 22, 2022	PlugFest Interoperability Event	Plantation FL

Subject to change. For more information, contact David Nardone, BACnet International, david@bacnetinternational.org or visit www.bacnetinternational.org

BACnet BASICS

Unfamiliar with BACnet
or need a refresher?

Check out this course
and **Earn CEUs!**



Education • Library • Community

thebacnetinstitute.org



BACnet International Journal 20

The BACnet International Journal is a global magazine for building automation based on BACnet technology. Experts, practitioners and professionals show the way in applying and developing the BACnet standard – from building automation trends to devices and application projects; from qualification and training to testing and certification; from who's who in the BACnet community to useful information on events and publications. Special attention is given to members and activities of BACnet International.

Online Distribution

The BACnet International Journal is posted to www.bacnetinternational.org and distributed to all members.

Editor

MarDirect Marketing Direct GbR
Bruno Kloubert

Responsible according to the press law
Aachener-und-Münchener-Allee 9
52074 Aachen, Germany
Phone: +49-241 88970-800
Fax: +49-241 88970-999
URL: www.bacnetjournal.org

ISSN 2191-7825

Board of Directors

Andy McMillan, President and Managing Director, BACnet International
Erica Johnson, Chair, QA Cafe
Brad Hill, Vice Chair, Honeywell International
Paul L. Bartunek, III, ABB
James Burke, Johnson Controls
Raj Jayaraman, Burton Medical
Raymond Rae, CopperTree Analytics
Dennis Swoboda, Blue Ridge Technologies
Michael R. Wilson, Automated Logic

Publisher

BACnet International
2900 Delk Road
Suite 700, PMB 321
Marietta, GA 30067
Phone: 770-971-6003
Fax: 678-229-2777
info@bacnetinternational.org

Advertising

MarDirect Marketing Direct GbR
Phone: +49-241-88970-801
Fax: +49-241-88970-999
E-mail: sistemich@mardirect.de

Picture Credits

BACnet International, MarDirect and specified companies

Copyright

© BACnet International 2021 – Further editorial use of articles in the BACnet International Journal is encouraged with reference to the source. Please send a specimen copy to publisher, or if published online, send the URL per email to info@bacnetinternational.org.

Important Legal Information

The Client is fully responsible for the content or legality of any third party materials supplied and the final published form and usage of these materials; in print, electronic, online etc. The Client is responsible for ensuring that the rights of third parties by publishing in print, electronic, online etc., or any other form of media are not affected. It protects the Contractor, if necessary, against any and all claims which are made by third party claimants. The Client indemnifies the Contractor free of any claims of copyright infringement. The Contractor is not obligated to check any orders and whether the rights of any third parties are affected by it.

BACnet™ is a trademark of the American Society of Heating, Refrigerating and Air Conditioning Engineers, Inc. (ASHRAE)

Versatile, Cloud Connected BACnet Edge Controllers



BASpi Edge Controllers



Ideal for standalone or BACnet supervised automation applications

- BACnet/IP client/server over Ethernet or Wi-Fi
- Azure IoT Central (SaaS) cloud connected
- Function block programming
- Graphical dashboard
- Schedules with holidays/exceptions
- Email alarms/notifications



LAS VEGAS / 2022
JAN 31- FEB 2
See us at Booth C974



Learn more at www.ccontrols.com/edge

the ART of Building Sustainability

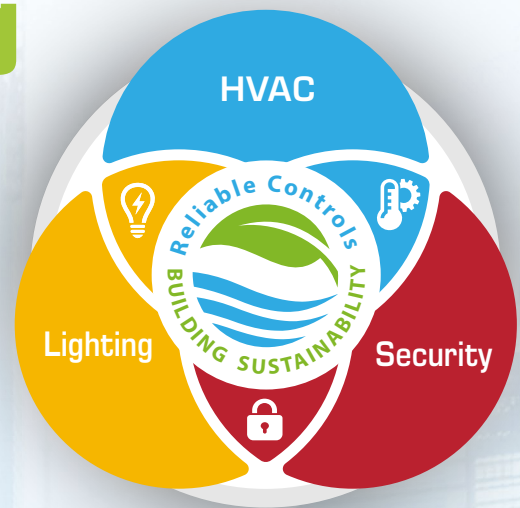

1 **CERTIFIED OPEN STANDARDS**

Ensure a strong level of interoperability by using open protocols which have third-party listing laboratories to verify adherence to your protocol's form and function.

2 **SECURE DATA**

Employ a single sign on (SSO) architecture with compliance to scalable credentialing architectures and secure tunneling methodologies such as BACnet Secure Networks (B/SN).

3 **INTEGRATED FAULT DETECTION & DIAGNOSTICS**

Specify integrated FDD (IFDD) that delivers real-time fault detection, step-by-step root-cause diagnostics while using all your existing cabling structures, including twisted-pair networks.

4 **OWNERSHIP OF ANALYTICS**

Insist on timely analytics for all stakeholders with complete control of formatting and scheduling while retaining full ownership of your data and the reports generated.

5 **SINGLE-APP EXPERIENCE**

Create better-connected spaces with real-time access to occupancy, lighting, ventilation, and thermal comfort levels, using a holistic single app on the occupant's mobile device.

Select lifecycle-centric manufacturers who minimize the negative impacts of waste with long-term warranty and repair services while adhering to WEEE, RoHS, R2, and LEED directives.

6 **MINIMAL WASTE**

Enjoy the long-term benefits of suppliers who engineer a path forward to new technologies while remaining backward compatible without third-party gateways or hardware replacement.

7 **BACKWARD COMPATIBLE**

Stay on top of regular advances in technology with supplier-certified, multi-lingual online educational videos, technical documentation, software updates, and advanced face-to-face classroom courses.

8 **TRAINING & SUPPORT**

Choose from a global network of factory-certified service partners who are passionate about long term, consistent, local support for you and your buildings.

9 **FACTORY-CERTIFIED SERVICE**

Sustainability requires a high level of integration between HVAC, lighting, and security systems. The art of building sustainability skillfully combines this integration with other technological and supporting elements that must endure over the long term. When these additional elements are maintained over the life of your building, true building sustainability emerges. To learn more about the ART of Building Sustainability please visit reliablecontrols.com/TABS

Better by design™



Reliable[®]
controls



Continually Raising Building Standards

BACnet International is an industry association that facilitates the successful use of the BACnet protocol in building automation and control systems through interoperability testing, educational programs and promotional activities.



BACnet is leading the world in Building Protocol Standard: It plays a significant role in building automation projects worldwide.



Achieving the Mark of Distinction: The BACnet Testing Laboratories (BTL) Mark provides users with assurance that a product has passed the industry standard BACnet conformance tests conducted by a recognized, independent testing organization. The BTL Mark is a mark of distinction, achieved by more than 1100 products, that many building owners and control system designers look for as a must-have in order to be eligible for a project.

► Discover More Today: www.bacnetinternational.org